



FSD-C Damper Installation, Operating & Maintenance Instructions

1 Health and Safety

- 1.1 Only competent personnel may carry out the work outlined in this document.
- 1.2 Wear appropriate Personal Protective Equipment as required for safe working conditions and as site rules dictate.
- 1.3 Do not introduce fingers across the open blade.
- 1.4 Where dampers are only accessible with the need for additional elevation, any equipment used should be done so with due consideration to the Work at Height regulations 2005 and current site rules.

2 Important

- 2.1 These instructions should be read in its entirety before commencing work. The installer must be Competent with the manufacturer's separating element construction.
- 2.2 PML Actuators are IP54 rated – Check actuator connection box is suitably located.
- 2.3 Do not cut/shorten the Thermal Fuse lead (-TF Actuators). This will render the unit inoperable and invalidate the warranty.
- 2.4 Refer to actuator label for wiring of actuator.
- 2.5 Refer to section 10 for testing.
- 2.6 For existing dry walls – When cutting the opening for damper, and (partial) removal of stud is unavoidable, ensure the structure is sufficiently supported to conform to design specification
- 2.7 Dry wall openings must be lined.
- 2.8 Ensure that appropriate 'fire-rated' plasterboard is used throughout the construction of drywall partitions that need to act as fire-barriers.
- 2.9 Ductwork to be fitted and connected in accordance with DW 144/145. Aluminum rivets should be used (to act as breakaway joint).
- 2.10 All installations are subject to local Building Control Approval (BCA). Tested Installations are detailed herein. If the proposed installation has minor variations to that shown, acceptance from BCA should be sought before proceeding. Manufacturers are not able to 'approve' specific installation methods.

3 Equipment required

- 3.1 Equipment and tools will vary dependent upon the fire barrier construction that the damper is being installed within. Standard equipment that are normally

used for the building of the particular barrier should suffice. Access-equipment as necessary.

- 3.2 8mm, 10mm for motor fixing and 12mm AF spanners to change blade position via drive shaft. Phillips №2 screwdriver for setting of OPEN position if required.
- 3.3 Cordless drill
- 3.4 Screwdriver to suit junction box terminals.

4 Preparation for Installation

- 4.1 Before installation, the damper should be inspected to ensure that it has not been damaged and is in good condition following transportation/on site storage.
- 4.2 Check damper reference and size to site specification.
- 4.3 Install damper to site specification details and building codes of practice. (Refer to Tested Installation Methods). Non-tested installations may be rejected by building control.
- 4.4 Ensure that the ductwork is independently and adequately supported.
- 4.5 Connecting ductwork should be connected with breakaway fixings such as aluminium rivets in accordance with DW144 and 145.
- 4.6 Note: All Fire / Smoke Damper installations must be carried out to the satisfaction of the appropriate Building Control officer and/or specifying authority. Where more than one duct penetrates a wall or floor, adjacent fire damper assemblies should be separated by a structural element with a minimum width of 200mm (to comply with BS EN1366-2 13.6).
- 4.7 Test damper (Refer to section 10)

Tested Installation Methods

5 Preparation

- 5.1 The installation method contained herein assumes the wall has been built prior to the damper opening preparation.
- 5.2 Determine required position of damper. Check sufficient space exists to fit the product. Ensure any services (e.g. electrical/plumbing) within the structure or running close to the structure will not be affected. If existing stud/track is avoidable, ensure the structure is sufficiently supported to conform to design specification and that the opening is lined.
- 5.3 When the structure is deeper than the casing length it may be necessary to connect ducting to the non-access side of the damper through the opening, before final fitting the damper. Once this is done slide the damper and ductwork assembly back through the opening until the Installation Plate butts up to the structural surface ready to be fixed.

6 Procedure

Dry wall Installation

- 6.1 Preferably, prepare opening whilst building wall, or cut opening if wall already exists.

- 6.2 The aperture must be 'lined out'.
- 6.3 Cut size = damper size + (2 x nominal gap size) + (2 x wall board thickness).
E.g. for 150mm dia. damper, and 12.5mm wall board, cut aperture should be 195mm (150+(2x10)+(2x12.5))
- 6.4 Mark out position and size of required cut size on the wall.

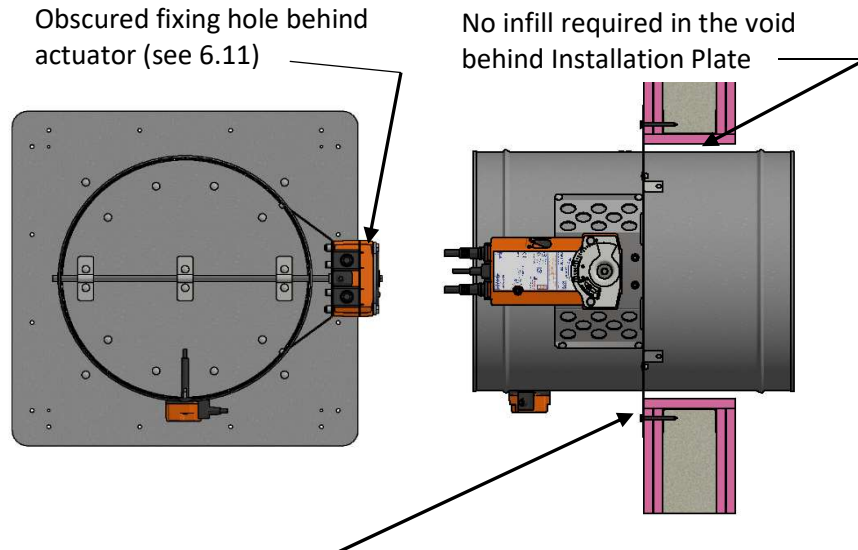

38mm long drywall screws to affix installation plate to metal frame within drywall (see 6.11)

- 6.5 Using appropriate means (e.g. jig saw), cut the aperture in the wall, removing each layer and any infill that is present
- 6.6 Cut 2 pieces of steel track 50mm+ longer than opening size.
- 6.7 Fit track to top and bottom of opening, screwing in position from both sides of wall at each end of track with drywall screws and at maximum 300mm centers.
- 6.8 Cut 2 more pieces of track, this time, equal opening size.
- 6.9 Fit track to sides of opening, screwing in position in a similar fashion as above.
- 6.10 Cut 4 pieces of board width to line the opening to the full width of the wall. Screw each baton with 2 screws to the track that is lining the opening. Ensure the access side baton is flush with the surface of the wall.
- 6.11 Position the damper centrally in wall opening (width/height), with blade axle running horizontally. Using drywall screws, fix Installation Plate to wall using drywall screws. **Important:** Ensure the screws 'pick up' the track lining the

aperture so that the proper fire integrity of the installation will not be compromised. Use either one of the two appropriate Ø5mm corner fixing holes and all Ø5mm mid-span fixing holes. Note for damper sizes of 100mm – 200mm dia, the mid span fixing behind the fitted actuator, can be omitted.

Block wall and Floor Installation

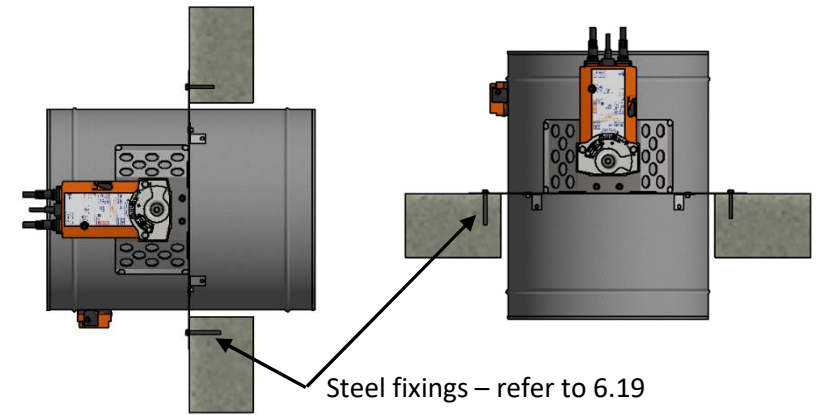

- 6.12 Preferably, prepare opening whilst building wall, or cut opening if wall already exists.
- 6.13 Cut size = finished size
- 6.14 E.g. for 250 dia. damper, cut aperture should be 270mm square (250+20)
- 6.15 Mark out the position and size of opening on the wall.
- 6.16 Using appropriate means, cut the aperture in the wall.
- 6.17 Position damper centrally in wall opening with blade axle running horizontally. Fix Installation Plate to wall. (See section 3)
- 6.18 There are a variety of proprietary fixings available. Fixings must be fire rated (steel, NOT aluminum or plastic). Check minimum dimension specification between fixing and edge of opening. BSB recommend steel anchor type bolts Ø5mm minimum).
- 6.19 Position the damper centrally in wall opening (width/height), with blade axle running horizontally. Using steel screws, fix Installation Plate to wall **Important:** Use either one of the two appropriate Ø5mm corner fixing holes and all Ø5mm mid-span fixing holes. Note for damper sizes of 100mm – 200mm dia, the mid span fixing behind the fitted actuator, can be omitted.

7 Actuator Orientation Change / Replacement

- 7.1 If required, the orientation may be changed to +90° or -90° from default 'in-line-with-duct'.
- 7.2 Ensure power to actuator is removed and allow actuator to travel to end position.
- 7.3 Unscrew the 8mm AF head screw (central motor retaining screw) and remove the set-point assembly
- 7.4 Remove the 10mm AF head screws (motor body retaining bolts). (It may be necessary to partially wind the actuator a few degrees with the aid of the manual reset key to release residual torque).
- 7.5 Remove the actuator and refit in new position without changing the blade's position.
- 7.6 Secure with the 10mm AF head screws (5Nm), followed by the 'snail stop assembly' and 8mm AF head screw (3Nm).
- 7.7 Test (refer to section 10).

8 Setting of Damper mid set-point Position (optional)

- 8.1 Dampers are supplied with actuators set to travel to 'fully open' position by default.
- 8.2 Optionally, dampers can be set so that the 'open position' is restricted to between 30° to 90° (60° range). This is for system air balancing purposes, should it be required.
- 8.3 To utilise set-point positioning, temporarily release actuator, unscrew and reposition the positional limiter engaging into the 2mm dia holes (as below).
- 8.4 Note: Wiring (section 9), If using "open damper status" indication.

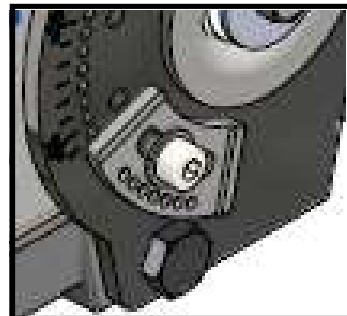
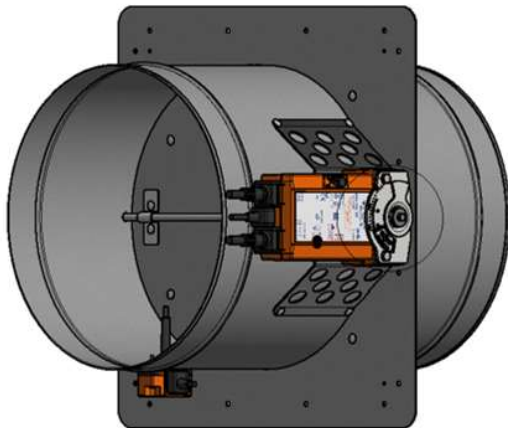

- 8.5 Retighten the retaining screw to approx. 3Nm.
- 8.6 Reapply power and check correct open position is attained.

9 Wiring

- 9.1 Refer to electrical specification on back page of this document.
- 9.2 Dampers are supplied with actuators factory fitted and tested.
- 9.3 Connect wires in accordance with the wiring details below. Test.
- 9.4 (Refer to section 10.2).

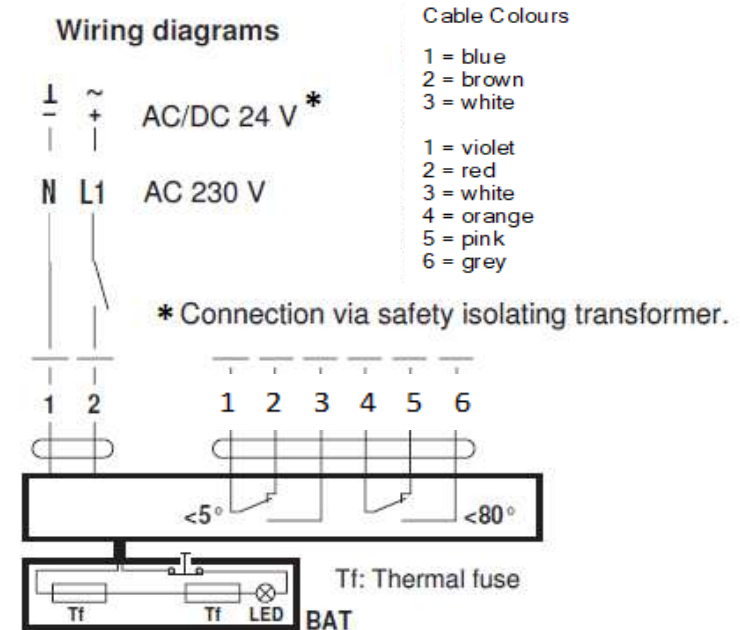

- 9.5 Make the following connections to achieve indication.
 - closed indication – use 1 & 2.
 - open indication when not using set point positions 4 & 6.
 - open indication when using set point positions 1 & 3

10 Commissioning, Maintenance and Test

- 10.1 In accordance with BS9999 Annex W.1, inspections should be undertaken at least annually, or more frequently where corrosive or dirty conditions prevail. The maintenance log should be reviewed at each inspection and the frequency adjusted as required dependent upon findings. (BSB also recommend a maximum of 1 year between inspections which should start more frequently initially and reduce frequencies only if conditions are proven to allow).
- 10.2 Check damper is in its 'normal state'.
- 10.3 If damper is not in its 'normal state', refer to fault finding chart otherwise continue.
- 10.4 As a pre-check BEFORE power is established – When the actuator orientation has been changed or the actuator has been replaced, it should be wound manually using the manual reset. If resistance is encountered – over-winding can result in permanent damage to the damper which may invalidate the warranty).
- 10.5 The actuator can be 'locked' open by winding manually with key provided, then locked and also released by rotating the black lever (next to the padlock symbol) on face of actuator.
- 10.6 Switch on power to actuator. LED on TF will illuminate, and actuator will start to travel to the DRIVE-END position. After 60 seconds, visually check that damper blade position and signaling corresponds.
- 10.7 IMPORTANT: Press and hold test switch button on the TF to allow damper to travel to its closed position. Visually check that the damper blade position and signal corresponds. (This is to ensure that the actuator functions electrically and overrides the manual reset facility, should it have been used, as it is feasible to leave the damper inadvertently reset without the TF being functional if this test is not carried out!)
- 10.8 Release TF button to allow damper to drive to normal position.
- 10.9 If damper has seized: -
- 10.10 Open the damper (even partially if possible). Clean the inside of the damper case where the blade seals make contact. Use a soft cloth with a light application of light lubricant. (Connect Duck Oil recommended).
- 10.11 From the outside of the case, lightly apply a light lubricant into blade axle bearings.
- 10.12 Remove excess lubricant.
- 10.13 It is important to log, and review maintenance frequency based on inspections and test history.
- 10.14 Use of heavy oils is not permitted, as this can lead to a build-up of dust/dirt on damper surfaces.
- 10.15 The PML actuator is maintenance-free.

11 Fault Finding

Symptom	Fault	Corrective Action
Damper not in its 'normal' state or Green LED on the Thermal Fuse (TF) is not illuminated	No power / incorrect supply	Check supply/terminations Check signal connections
	TF tripped. Remove TF from duct, separate two halves, continuity check the two contacts within the probe section (or test with new probe)	If open circuit, replace probe
	Actuator faulty	Replace
Damper does not travel fully open / closed	Damper seized	Clean and lubricate. (Refer to section 10.9)
	Casing dented/damaged or not round	Minor damage may be corrected carefully with a mallet. (BSB always recommend replacement of damaged dampers)
	Foreign body interfering with blade sweep (commonly rivet or screw)	Inspect inside of damper case. Remove any offending item
Damper blade and/or actuator does not move open	Damper internals have been exposed to excessive moisture	Gently apply pressure to blade by hand to move open. Use Scotch Bright pad RED 07447 grade, wet with duck oil and clean the damper internally at the point where the blade closes. Wipe dry and leave clean. 'Massage' exposed peripheral blade seal until pliable.
Report and log any damage found with actions to be taken.		

Electrical details

24V

Nominal voltage	AC/DC 24 V
Nominal voltage frequency	50/60 Hz
Nominal voltage range	AC 19.2...28.8 V / DC 21.6...28.8 V
Power consumption in operation	4 W
Power consumption in rest position	1.4 W
Power consumption for wire sizing	6 VA
Power consumption for wire sizing note	I _{max} 8.3 A @ 5 ms
Auxiliary switch	2 x SPDT
Switching capacity auxiliary switch	1 mA...3 (0.5 inductive) A, AC 250 V
Switching points auxiliary switch	5° / 80°

230V

Nominal voltage	AC 230 V
Nominal voltage frequency	50/60 Hz
Nominal voltage range	AC 198...264 V
Power consumption in operation	5 W
Power consumption in rest position	2.1 W
Power consumption for wire sizing	10 VA
Power consumption for wire sizing note	I _{max} 4 A @ 5 ms
Auxiliary switch	2 x SPDT
Switching capacity auxiliary switch	1 mA...3 (0.5 inductive) A, AC 250 V
Switching points auxiliary switch	5° / 80°

Installation Check List

DAMPER REFERENCE NO.:		DAMPER LOCATION:	
DAMPER SIZE: Dia (mm)			
WALL/FLOOR APERTURE SIZE ('OPENING SIZE')			
WIDTH		HEIGHT	
DAMPER INSTALLED BY:			
(Print name)			
Signature:		Company:	Date:
ACTUATOR ELECTRICALLY CONNECTED BY:			
(Print name)			
Signature:		Company:	Date:
Actuator mid-point setting (circle)			
30° 35° 40° 45° 50° 55° 60° 65° 70° 75° 80° 85° 90°			
THERMAL FUSE FITTED BY:			
(Print name)			
Signature:		Company:	Date:
FAIL-SAFE POSITION (POWER OFF position) – Tick appropriate			
CLOSED (default) <input type="checkbox"/>		OPEN (non-std) <input type="checkbox"/>	
FINAL INSPECTION BY:			
(Print name)			
Signature:		Company:	Date:

Rev M 202

BSB Engineering Services Ltd
Tel +44 (0)1795 422609

Email: enquiries@bsb-dampers.co.uk website: www.bsb-dampers.co.uk